

Dec. 27, 1955

M. A. MIRANDO

2,728,159

BAYONET

Filed Dec. 11, 1952

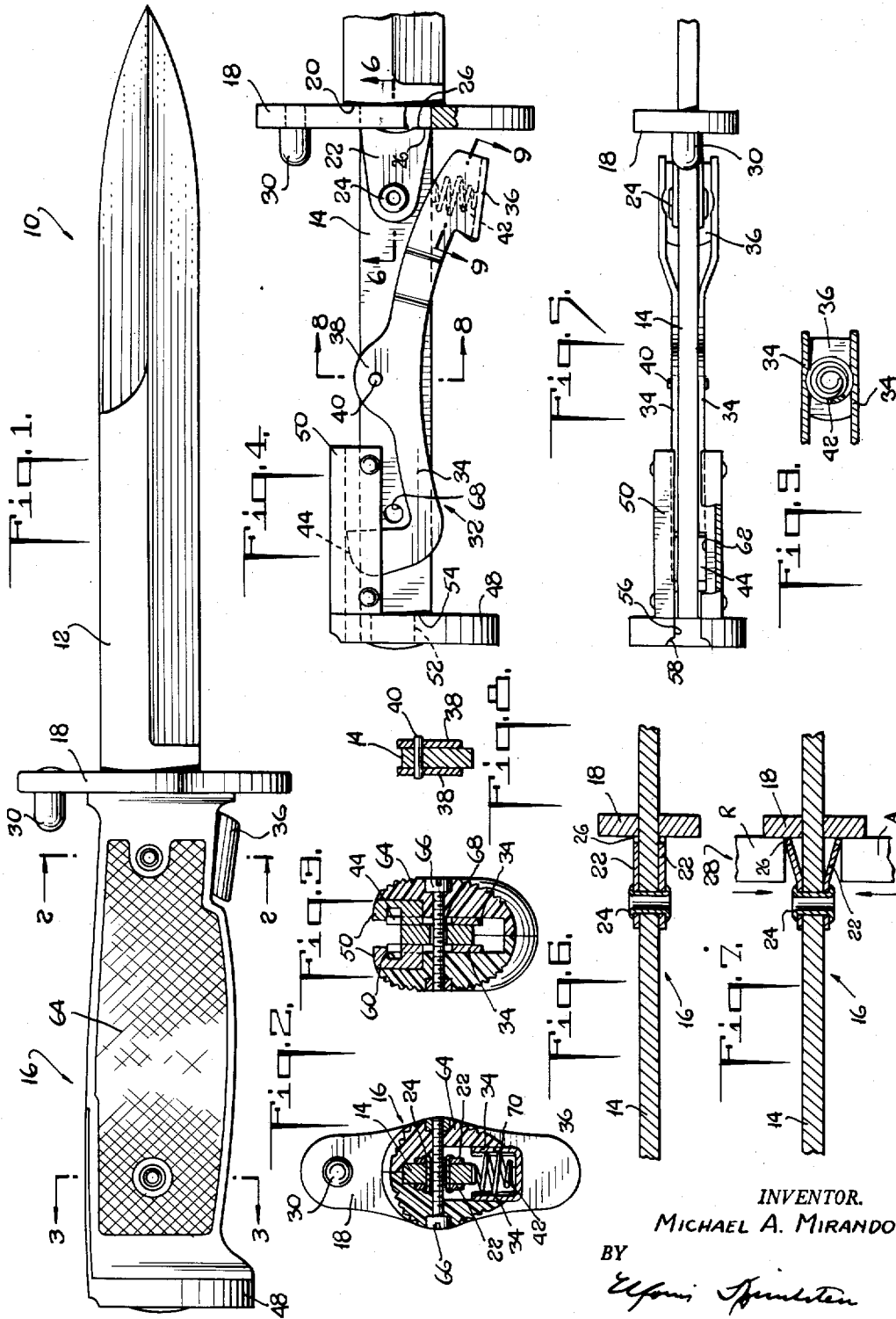

INVENTOR.  
MICHAEL A. MIRANDO  
BY  
*Elford Spindler*  
ATTORNEY

1

2,728,159

BAYONET

Michael A. Mirando, Providence, R. I., assignor to Imperial Knife Company, Inc., Providence, R. I., a corporation of Rhode Island

Application December 11, 1952, Serial No. 325,317

1 Claim. (Cl. 42-86)

This invention relates to bayonets.

It is another object of the present invention to provide a bayonet which can be secured to the gas chamber of a conventional rifle without any alteration to the rifle at the point of attachment.

It is another object of the present invention to provide a bayonet of the character described having a releasing and automatic locking lever which, although made from sheet metal, can be manipulated by a gloved hand.

It is another object of the present invention to provide a bayonet having a lever of the character described which is not cantilever mounted and hence is particularly smooth, positive and reliable in operation.

It is another object of the present invention to provide a bayonet having a lever of the character described which locks at two points instead of the usual one.

It is another object of the present invention to provide a bayonet of the character described which can be effectively welded or locked to a rifle even when the handle cover is removed.

Other objects of the invention will in part be obvious and in part will be pointed out hereinafter.

The invention accordingly consists in the features of construction, combinations of elements and arrangements of parts which will be exemplified in the bayonet hereinafter described and of which the scope of application will be indicated in the appended claims.

In the accompanying drawing in which is shown one of the various possible embodiments of the invention,

Fig. 1 is a side view of a bayonet constructed in accordance with the present invention;

Figs. 2 and 3 are sectional views taken substantially along the lines 2-2 and 3-3 of Fig. 1;

Fig. 4 is a side view of the bayonet handle with the cover pieces removed;

Fig. 5 is a top view of the bayonet handle as shown in Fig. 4;

Fig. 6 is a sectional view taken substantially along the line 6-6 of Fig. 4;

Fig. 7 is a view similar to Fig. 6 but illustrating the handle during press mounting of the guard; and

Figs. 8 and 9 are sectional views taken substantially along the lines 8-8 and 9-9, respectively, of Fig. 4.

Referring now in detail to the drawings, the reference numeral 10 denotes a bayonet constructed in accordance with the present invention and having a blade 12 with an integral shank 14 which constitutes the spine of the handle 16. The blade and shank can be stamped out in one piece from heavy sheet stock of proper metallurgical composition. There thus are eliminated the costly, time-consuming and intricate operations heretofore employed when the blade and shank of a bayonet were conventionally made by forging.

A guard 18 at the base of the blade is formed with a rectangular opening to admit the shank, the guard being seated on shoulders 20 between the blade and shank.

To hold the guard against the shoulder, I provide tri-

2

angular plates 22 disposed on opposite sides of the shank and permanently secured to the shank, as by a tubular rivet 24. The distance between the guard and the rivet hole in the shank when the guard abuts the shoulders is slightly less than the distance between the rivet hole in a plate and the front edge 26 of the plate. Prior to mounting, the plates are bent outwardly just forward of the rivet holes to an extent such that, as shown in Fig. 7, when the rivet 24 is tightened the front edges 26 of the plates will lightly hold the guard against the shoulders. Thereafter, the handle of the bayonet is placed between the ram R and anvil A of a press 28 which bend the plates into juxtaposition with the shank, thereby creating a pressure which tightly holds the guard against the shoulder. To aid in obtaining symmetrical pressure the center of each plate may be notched as shown.

A button 30 is secured to the guard adjacent its top, said button facing rearwardly and being adapted to register with the hole in the end of the gas chamber of a conventional rifle, thereby enabling the bayonet to be suspended from the gas chamber without having to change or add to the rifle at this point.

The locking and releasing assembly comprises a lever 32 fabricated from sheet metal by a blanking and folding operation so that it has two arms 34 joined at its front end by a broad operation pad 36. The centers 38 of the arms are enlarged and pierced in registration to rotatably receive the opposite ends of a pin 40 which is fixed in the shank transversely and protrudes from opposite sides thereof. It will be observed that this enlargement provides a pair of spaced bearings for the lever and thus obtains a smoother and more positive and reliable action than was secured heretofore with the conventional single cantilever bearing.

The pad 36 which constitutes the bayonet release member is biased downwardly by a spring 42 caught under compression between said pad and the lower edge of the shank.

Latching fingers 44 integral with the rear ends of the arms 34 are located on opposite sides of the shank and project above the top thereof when the pad is in idle, i. e. lowermost, position. Sufficient space is provided between the pad and shank to permit the fingers to be depressed to the level of the shank. Pushing the pad upwardly toward the shank against the restoring force of the spring 42 thus will enable the latching fingers to be lowered to clear the shank.

The T-slot is formed from four pieces, to wit, the shank 14, a flat end plate 48 and a pair of tracks 50. The plate 48 is centrally apertured to receive a toe 52 projecting from the rear end of the shank. The plate is seated against shoulders 54 at the base of the toe, the tip of the toe being peened to hold the plate in place. A T-slot 56 is milled through the end plate with the base of the slot aligned with the top of the shank and the side branches of the slot symmetrically protruding beyond opposite sides of the shank. The rear end 58 of the slot is flared to provide a lead for entry of the standard T-piece of a rifle. The tracks 50 are secured, as by riveting, to the shank on opposite sides thereof and immediately in front of the end plate. The tracks protrude above the shank and are formed on their facing surfaces with channels 60 that constitute a continuation of the side branches of the T-slot 56 in the end plate. The space between the upper portions of the tracks (see Fig. 3) constitutes a continuation of the stem of the T-slot in the end plate.

Each track has a vertical groove 62 facing the shank and disposed to pass a latching finger 44. The upper edges of said fingers project above the shank, as already described, extending into the T-slot and abutting against

3

the upper sides of the channels 60, thus defining the idle position of the operation pad.

The bayonet is attached to a rifle by inserting the button in the gas chamber opening (not shown) and simultaneously sliding the T-piece (not shown) into the T-slot. The rear edges of the latching fingers are rounded so that the T-piece on insertion will cam said fingers down. After the T-piece has passed them, the fingers will snap back into place behind it locking the bayonet to the rifle.

To release the bayonet the pad is pressed toward the shank and the bayonet slid off the rifle.

The bayonet appearance is finished and the locking and releasing assembly protected by cover pieces 64 fitted on each side of the shank blade and suitably secured thereto as by nuts and bolts 66, one bolt passing through an opening 68 near the rear of the handle portion and the other bolt passing through the tubular rivet 24. Said handle pieces are provided with openings 70 to pass the operation pad.

It thus will be seen that there is provided a bayonet which achieves all the objects of the invention and is well adapted to meet the conditions of practical use.

As various possible embodiments might be made of the above invention, and as various changes might be made in the embodiment above set forth, it is to be understood that all matter herein described, or shown in the accompanying drawing, is to be interpreted as illustrative and not in a limiting sense.

4

Having thus described the invention, there is claimed as new and desired to be secured by Letters Patent:

A bayonet comprising a blade having an integral shank, cover pieces, means mounting the cover pieces on the shank, a lever including two arms on opposite sides of the shank and a broad operating pad joining said arms beneath the shank, a pin carried by the shank and extending outwardly on both sides thereof to rotatably support said arms on opposite sides of the shank independently of the cover piece mounting means, a spring biasing the pad away from the shank, latching members on the arms on the ends opposite from the pad, and means engaged by the latching members to limit movement of the lever under influence of the spring.

#### References Cited in the file of this patent

##### UNITED STATES PATENTS

437,081	Bailey	Sept. 23, 1890
1,166,557	Stergianopulos	Jan. 4, 1916
1,237,330	Hammond	Aug. 21, 1917
1,886,567	Marble	Nov. 8, 1932
2,333,379	Johnson	Nov. 2, 1943
2,367,212	Haag	Jan. 16, 1945
2,455,361	Garand	Dec. 7, 1948
2,568,833	Storch	Sept. 25, 1951
2,615,247	Waters	Oct. 28, 1952